

SERIES 950

UNIDIRECTIONAL KNIFE GATE VALVES

2" to 12" 150psi (10bar)

14" to 24" 75psi (5bar)



FEATURES & BENEFITS

DESIGN FEATURES

Engineered for general purpose on/off service and isolation of clean, dirty, corrosive, abrasive, viscous and high temperature media.

- 1 Topworks designed for easy, quick conversion between manual and pneumatic actuation. Manual valves include a lubricant injection port for continuous, smooth operation with minimal maintenance.
- 2 Clevis design and horizontal bolting stabilizes gate ensuring proper alignment.
- 3 Standard multi-layer square packing provides exceptional gland sealing.
- 4 Optional energized quad seal packing for enhanced gland sealing.
- 5 Standard integral metal seat and optional replaceable zero leakage resilient seats.
- 6 Gate design ensures consistent alignment throughout the length of the stroke.
- 7 Unique body design with no dead pockets enables self-draining of valve.

APPLICATIONS

Wastewater

- > Slurry/Sludge Lines

General Industrial

- > Pneumatic Conveyance
- > Raw & Treated Water
- > Water Conveyed Solids
- > Dry Media | Cement
- > Hot Gases

Mining

- > Mineral Mining
- > Coal Washeries
- > Coal Preparation

Pulp & Paper

- > Paper Stock
- > Liquor Services

Power

- > Fly Ash | Bottom Ash
- > Branch Lines

Chemical

- > Pellets
- > Process Fluids & Chemicals
- > Petroleum Products

Food & Beverage

- > Winery
- > Dairy Processing

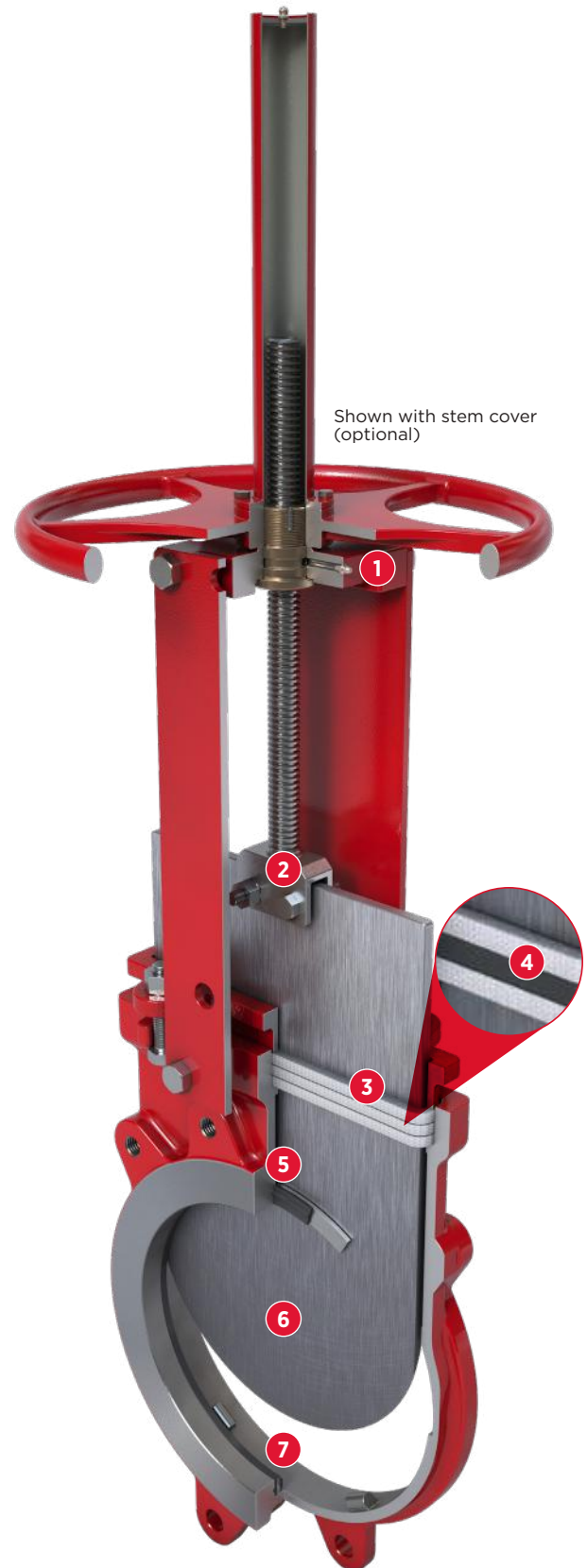

Shown with replaceable resilient seat (optional)

Series 950 Semi Lug Style

TECHNICAL SPECIFICATIONS

Size Range	NPS 2 to 24 DN 50 to 600
Body Style	Single piece Semi-Lug
Pressure Rating	2-12 150psi 50-300mm 10 bar 14-24 75psi 350-600mm 5 bar
Drilling	ASME B16.5 CL150
Face to Face	MSS SP-81
Certification	Canadian CRN, PED, ATEX, AWWA C520 2019
Design Standard	MSS SP-81
Testing Standard	MSS SP-151

STANDARD CONSTRUCTION

Body	DI
Gate	304
Seat	Integral
Stem	304
Gland	CS
Packing	PTFE Impregnated Synthetic Fiber
Topworks	CS

GATE OPTIONS

304, 316, 317 Stainless Steel
SAF 2507 Duplex
17-4PH Stainless Steel
Hastelloy® C
Monel®
Titanium

BODY OPTIONS

Carbon Steel (WCB)
CF8 Stainless Steel
CF8M Stainless Steel
CF3M Stainless Steel
SAF 2205 Duplex
SAF 2507 Duplex

PACKING MAXIMUM TEMPERATURE RANGE

Pure PTFE	500°F
	260°C
PTFE Impregnated Synthetic Fiber	450°F
	232°C
PTFE w/Buna-N Quad Seal¹	194°F
	90°C
PTFE w/Viton® Quad Seal¹	392°F
	200°C
PTFE w/EPDM Quad Seal	248°F
	120°C
PTFE w/Copper Wiper¹	500°F
	260°C
Graphite	1202°F
	650°C



Pure PTFE



PTFE Impregnated Synthetic Fiber



PTFE w/Buna-N Quad Seal



PTFE w/Viton® Quad Seal



PTFE w/EPDM Quad Seal



PTFE w/Copper Wiper



Graphite

NOTE ¹ Pure PTFE or PTFE Impregnated Synthetic Fiber can be used.

SEAT OPTIONS

Standard integral metal seat and optional replaceable zero leakage resilient seat.



Buna-N	-34 to 194°F
	-36 to 90°C
EPDM	-65 to 248°F
	-54 to 120°C
Viton®	-15 to 392°F
	-26 to 200°C

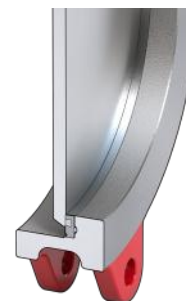

PTFE w/Viton Back-up Ring**	-235 to 392°F
	-148 to 200°C

** Allowable seat leakage as per MSS SP-151 metal seated valves

MATERIALS OF CONSTRUCTION

MATERIAL SPECIFICATIONS & PARTS CALLOUT

ITEM	DESCRIPTION	MATERIAL
1	Body	DI
2	Gate	304 Stainless Steel
3	Packing Set	Synthetic Fibre PTFE Impregnated
4	Gland	Carbon Steel
5	Gland Bolt	304 Stainless Steel
6	Gland Washer	304 Stainless Steel
7	Gland Nut	316 Stainless Steel
8	Side Plate	Carbon Steel
9	Mounting Bolt (Top)	304 Stainless Steel
10	Mounting Nut (Top)	316 Stainless Steel
11	Mounting Bolt (Bottom)	304 Stainless Steel
12	Spring Washer	304 Stainless Steel
13	Clevis	304 Stainless Steel
14	Stem	304 Stainless Steel
15	Clevis Bolt	304 Stainless Steel
16	Clevis Nut	316 Stainless Steel
17	Collar	Ductile Iron
18	Yoke Sleeve	Aluminum Bronze
19	Grease Nipple	Bronze
20	Thrust Washer	Aluminum Bronze
21	Hand Wheel	Cast Iron
22	Socket Screw	Carbon Steel
23	Seat ¹	EPDM

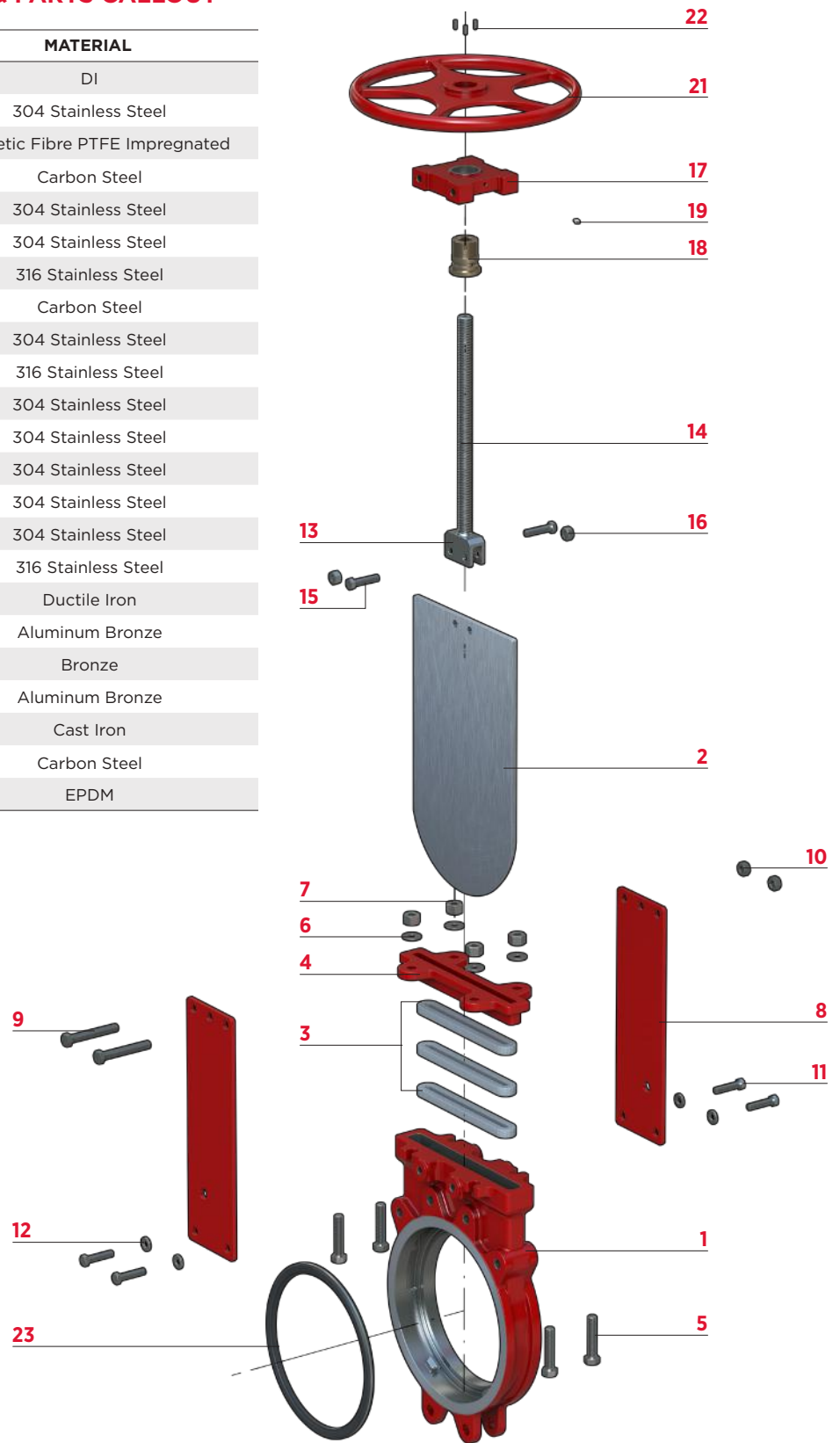

NOTE
1 Optional replaceable resilient seat.

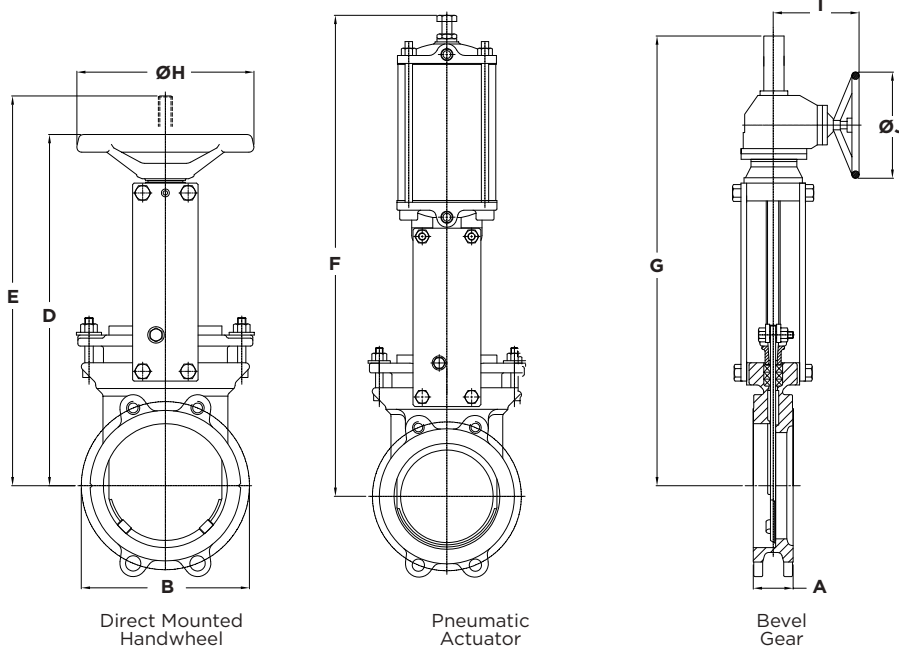

NOTE

- 1 Consult factory for hydraulic and electric actuator dimensions.
- 2 Dimensions are approximate and subject to change. Consult factory for certified drawings.

* In conformance with ASME B16.5, Class 150 for sizes NPS 2 (DN50) through NPS 24 (DN600.)

DIMENSIONS (Inches)									
NPS	A	B*	D	E	F	G	ØH	I	ØJ
2	1.88	4.75	13.03	13.94	19.17	--	8.00	--	--
3	2.00	6.00	15.71	18.43	22.80	--	8.00	--	--
4	2.00	7.50	17.32	21.10	25.39	--	8.00	--	--
5	2.25	8.50	19.41	23.90	28.35	--	10.00	--	--
6	2.25	9.50	20.91	26.34	31.65	--	10.00	--	--
8	2.75	11.75	24.84	32.28	38.74	35.63	12.00	11.65	20.00
10	2.75	14.25	27.28	37.68	44.21	41.06	16.00	11.65	20.00
12	3.00	17.00	30.67	43.11	51.22	47.80	16.00	11.65	20.00
14	3.00	18.75	33.66	47.72	54.96	49.80	20.00	12.05	20.00
16	3.50	21.25	37.01	52.83	63.07	55.12	20.00	12.05	20.00
18	3.50	22.75	41.85	60.04	70.28	61.93	20.00	12.05	20.00
20	4.50	25.00	46.34	66.10	76.34	68.39	20.00	12.05	20.00
24	4.50	29.50	54.06	77.99	89.92	80.04	20.00	12.05	20.00

WEIGHT (lbs)		
HAND WHEEL	PNEUMATIC ACTUATOR	GEAR OPERATOR
20	35	--
29	44	--
35	55	--
53	84	--
55	88	--
79	132	99
132	220	179
176	324	198
254	418	298
324	496	397
408	584	463
573	805	650
672	937	772

DIMENSIONS (Millimeters)									
DN	A	B*	D	E	F	G	ØH	I	ØJ
50	48	120.7	331	354	487	--	203	--	--
80	51	152.4	399	468	579	--	203	--	--
100	51	190.5	440	536	645	--	203	--	--
125	57	215.9	493	607	720	--	254	--	--
150	57	241.3	531	669	804	--	254	--	--
200	70	298.5	631	820	984	905	305	296	508
250	70	362.0	693	957	1123	1043	406	296	508
300	76	431.8	779	1095	1301	1214	406	296	508
350	76	476.3	855	1212	1393	1265	508	306	508
400	89	539.8	940	1342	1602	1400	508	306	508
450	89	577.9	1063	1525	1785	1573	508	306	508
500	114	635.0	1177	1679	1939	1737	508	306	508
600	114	749.3	1373	1981	2284	2033	508	306	508

WEIGHT (kg)		
9	16	--
13	20	--
16	25	--
24	38	--
25	40	--
36	60	45
60	100	80
80	147	90
115	190	135
147	225	180
185	265	210
260	365	295
305	425	350

OPTIONS & ACCESSORIES

ACTUATOR OPTIONS | SHOWN IN RED



Direct Mounted Handwheel



Bevel Gear Operator



Double Acting Pneumatic Actuator



Hydraulic Actuator

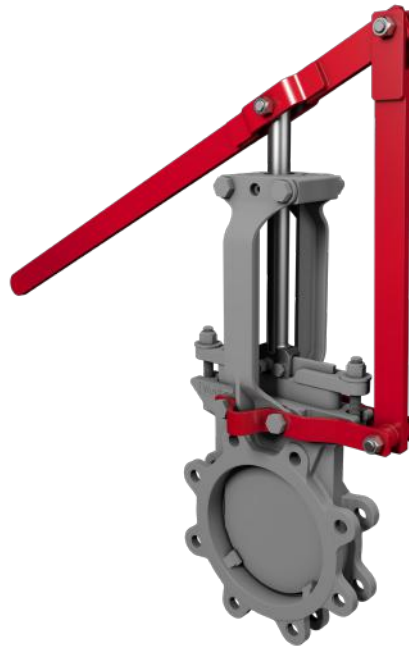

Lever



Electric Actuator

ADDITIONAL ACCESSORIES | SHOWN IN RED

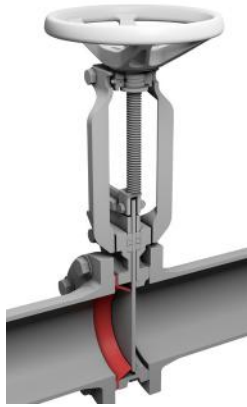

Deflection Cone



Handwheel Lock Out



Pinned Lockout Open & Closed



Pneumatic Failsafe



Non-Rising Stem



Gate Guard



Manual Override



Chain Wheel



Mechanical Limit Switch



Positioner



Proximity Sensor



Bonnet



BRAY FLOW CONTROL SOLUTIONS ARE AVAILABLE FOR A VARIETY OF INDUSTRIES.

ENERGY

Mining
Oil & Gas
Power / FGD
Nuclear Power

WATER

Water / Wastewater
Ultra Pure Water
Desalination
Irrigation

INDUSTRIAL

Chemical
Pulp & Paper
Textile
Marine

INFRASTRUCTURE

Beverage & Food
Transportation
Heating, Ventilation & Air Conditioning (HVAC)



US HEADQUARTERS

Bray International, Inc.
13333 Westland East Blvd.
Houston, Texas 77041
Tel: 281.894.5454

CHINA HEADQUARTERS

Bray Controls (ZheJiang) Co. Limited
98 GaoXin # 6 Road
XiaoShan Economic & Development Zone
HangZhou, ZheJiang 311231, P.R. China
Tel: 86 571 8285 2200

EUROPE HEADQUARTERS

Bray Armaturen & Antriebe Europa
Halskestraße 25
47877 Willich
Germany
Tel: +49 2154 8875-0

INDIA HEADQUARTERS

Bray Controls India Pvt. Ltd.
Plot No. H-18 & H-19
SIPCOT Industrial Park
Vallam Vadagal, Echoor Post
Sriperumbudur Taluk
Kancheepuram District
Tami Nadu - 631 604
Tel: +91-44-67170100



THE SMART CHOICE FOR FLOW CONTROL SINCE 1986.
WITH MORE THAN 300 LOCATIONS WORLDWIDE,
FIND A REPRESENTATIVE NEAR YOU AT **BRAY.COM**

All statements, technical information, and recommendations in this bulletin are for general use only. Consult Bray representatives or factory for the specific requirements and material selection for your intended application. The right to change or modify product design or product without prior notice is reserved. Patents issued and applied for worldwide.